

SPIDER CRANE
MC305C-2

TECHNICAL DATA

Metric(CE)

Specifications

Crane Capacity	2.98t x 2.5m
Max. Working Radius	12.16m x 0.26t
Max.Lifting Height	12.52m
Max. Reach Below Ground	-16.09m (4 falls)
Outrigger Max.Extended Width	(Lateral) 4,888mm x (Front) 4,504mm x (Rear) 4,396mm
Travel Speed	0-2.8km/h
Travel Ground Pressure (MC305CRM-2)	36.3kpa [0.37kgf/cm ²]
Travel Ground Pressure (MC305CRME-2)	37.3kpa [0.38kgf/cm ²]
Engine	YANMAR 3TNV76 / Diesel
Engine Rated Output	15.2kw/2,500rpm
Electric Motor	5.5kw, 4P 380V
Dimensions	4,285mm (L) x 1,280mm (W) x 1,695mm (H)
Machine Weight	3,900kg (4,080kg with electric motor)

Dimensions

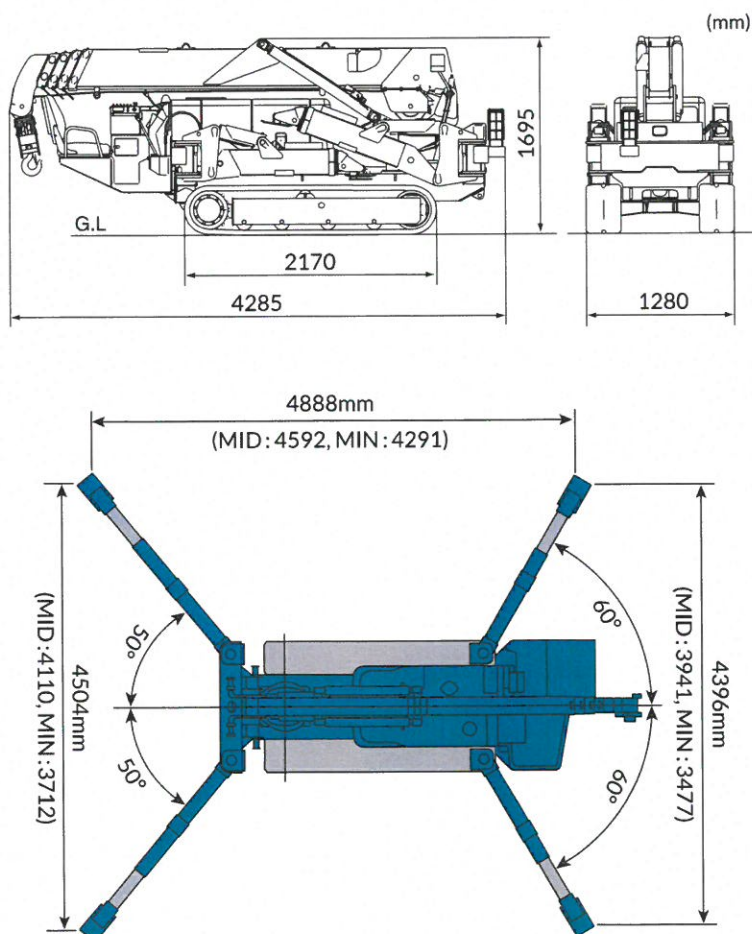

SPIDER CRANE
MC305C-2

TECHNICAL DATA

Metric(CE)

Working Range Chart

Outriggers Position : Max

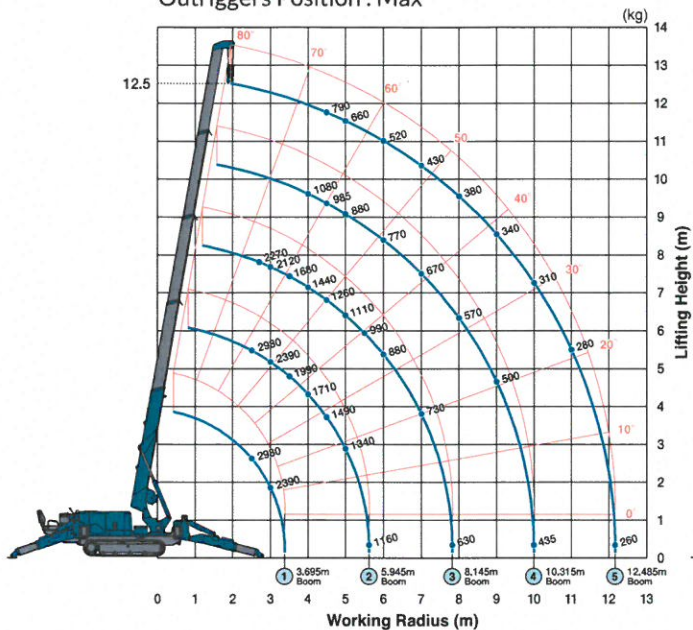

Outriggers Position : Mid

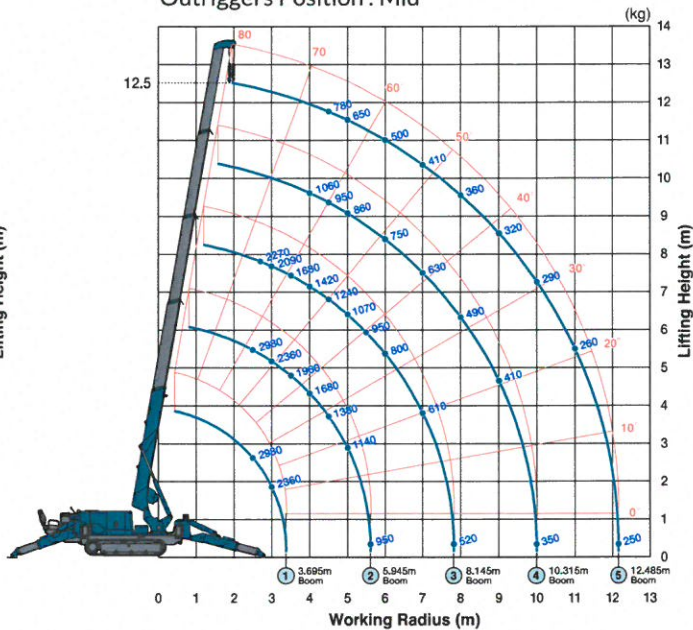

Outriggers Position : Min

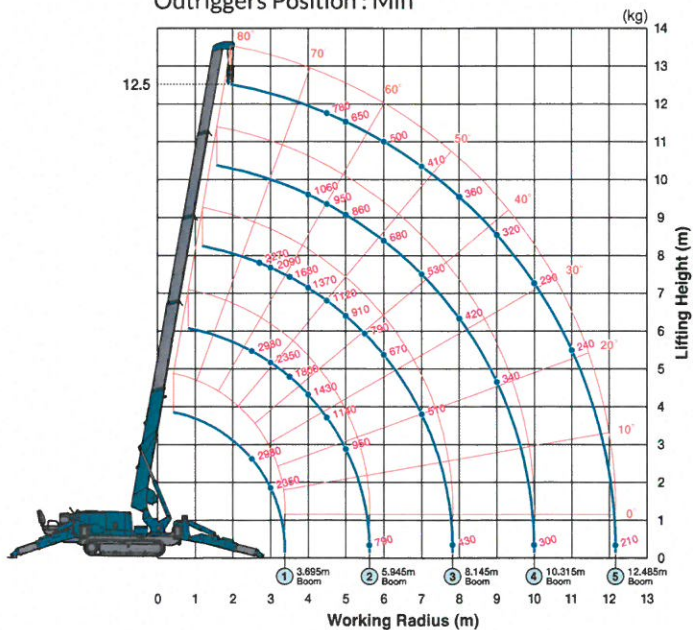

Max. Below Grade

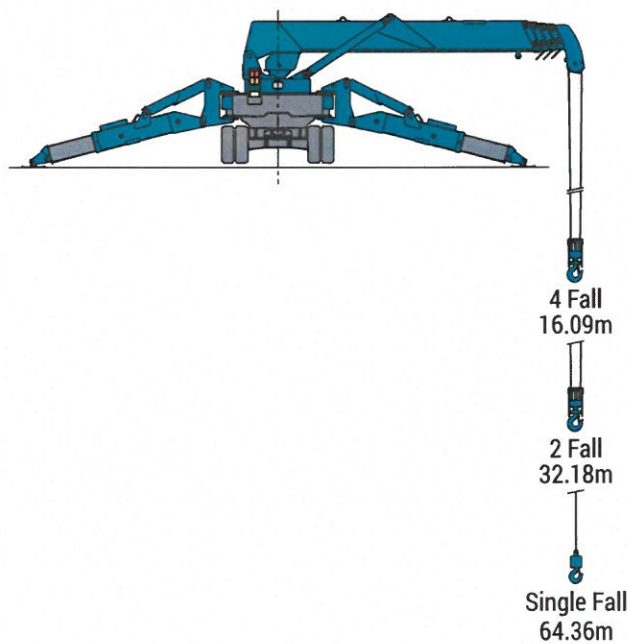

SPIDER CRANE
MC305C-2

TECHNICAL DATA

Metric(CE)

Working Range Chart

850kg Searcher Hook

850kg Searcher Hook Offset Position : SH1
(Outriggers Position : Max)

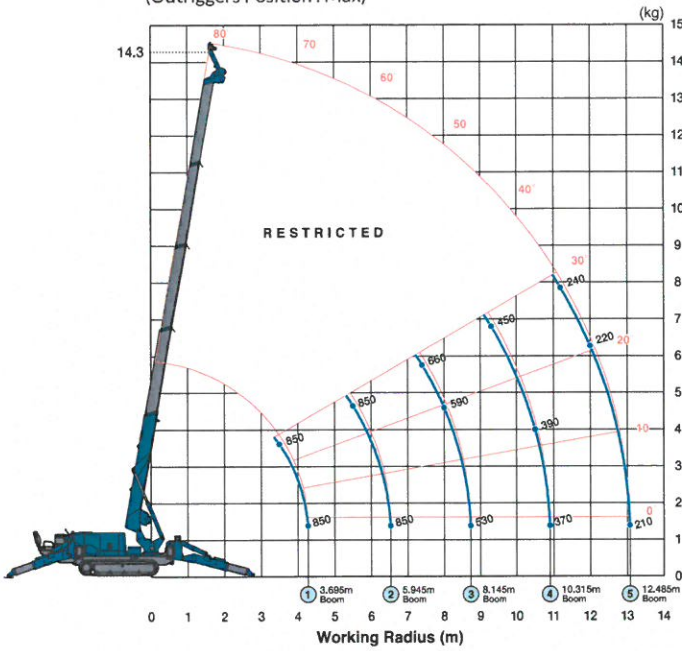

850kg Searcher Hook Offset Position : SH2
(Outriggers Position : Max)

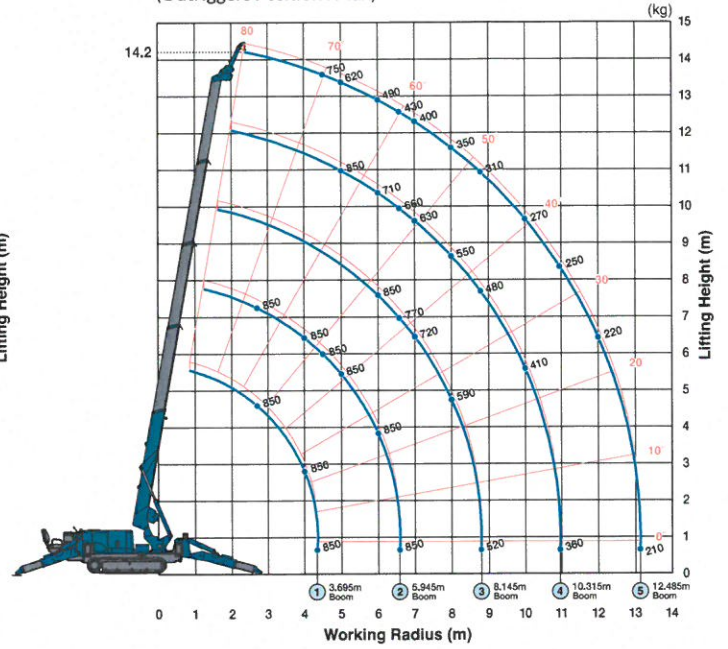

850kg Searcher Hook Offset Position : SH3
(Outriggers Position : Max)

